

Pediatric glucose regulation without pre-meal insulin boluses: an approach based on switched control and time-varying IOB constraints

Emilia Fushimi ^{*,**,†} María Cecilia Serafini ^{*,***}
Ricardo Sánchez-Peña ^{**,****} Hernán De Battista ^{*,**}
Fabricio Garelli ^{*,**}

^{*} *Grupo de control aplicado (GCA), Instituto LEICI, Facultad de Ingeniería, UNLP-CONICET, La Plata, Buenos Aires, ARG*

^{**} *Consejo Nacional de Investigaciones Científicas y Técnicas (CONICET), ARG*

^{***} *Comisión de Investigaciones Científicas de la Provincia de Buenos Aires (CICpBA), ARG*

^{****} *Instituto Tecnológico de Buenos Aires (ITBA), Ciudad Autónoma de Buenos Aires, ARG*

[†] *emilia.fushimi@ing.unlp.edu.ar*

Abstract: Artificial pancreas (AP) systems have shown to improve glucose regulation in type 1 diabetes (T1D) patients. However, full closed-loop performance remains a challenge particularly in children and adolescents, since these age groups often present the worst glycemic control. In this work, a new algorithm based on switched control and time-varying insulin-on-board (IOB) constraints is presented (ARG_{AE}). This method is a combination of ideas from the previously introduced Automatic Regulation of Glucose (ARG) algorithm, which features no pre-meal insulin boluses, and the Amplitude Enable (AE) mode, which allows the controller to act more aggressively at the beginning of meal intake without risking postprandial hypoglycemia. The proposed control strategy is evaluated *in silico* and its performance contrasted with the ARG algorithm in the pediatric population. **Results show that the ARG_{AE} presents improved performance compared to the ARG algorithm even in presence of misclassified meals. Thus, future *in vivo* testing will involve the AE configuration.**

Keywords: Artificial pancreas, Switched control, Sliding mode, Non-linear control systems, Biological and medical systems

1. INTRODUCTION

Artificial pancreas (AP) systems consist of a subcutaneous insulin pump connected to a continuous glucose monitoring (CGM) sensor through a control algorithm that automatically calculates insulin doses according to CGM measurements (Haidar, 2016). Unfortunately, the subcutaneous route introduces considerable issues, including large delays in glucose measurements and insulin action (Bequette, 2012).

The vast majority of AP systems are based on model predictive control (MPC) (Shi et al., 2019; Abitbol and et. al., 2018), proportional-integral-derivative (PID) (Steil, 2013) and fuzzy logic (FL) (Mauseth et al., 2013) (see Sánchez-Peña and Chernavvsky (2019) for a thorough description of the current situation). Since high model uncertainty and large delays limit the autonomy of the glucose controller, most of these control systems are hybrid, i.e., a combina-

tion of manual meal boluses and automatic basal modulations. However, carbohydrates (CHO) counting implies an important burden and risk for people with diabetes (Brazeau and et. al., 2013). Therefore, a purely feedback solution is necessary.

Recently, a control algorithm without pre-meal insulin boluses called Automatic Regulation of Glucose (ARG) was proposed and clinically evaluated in five adult subjects with type 1 diabetes (T1D) at the Hospital Italiano de Buenos Aires (HIBA) (Sánchez-Peña and et. al., 2018). This algorithm consists of an inner switched linear quadratic gaussian (SLQG) controller and an outer sliding mode safety layer called Safety Auxiliary Feedback Element (SAFE) (Revert et al., 2013). The inner controller switches between an aggressive LQG controller to compensate for the effect of meals and other large perturbations, and a conservative LQG controller to maintain normoglycemia at all other times (see also Colmegna et al. (2018)). A meal announcement is required at meal times to trigger a *listening* mode in which the controller waits to detect an increasing trend on CGM readings to switch to

* Research in this area is supported by the Argentine government (PICT 2017-3211 Agencia Nacional de Promoción Científica y Tecnológica, PIP 112-201501-00837 CONICET, and UNLP 11/I216).

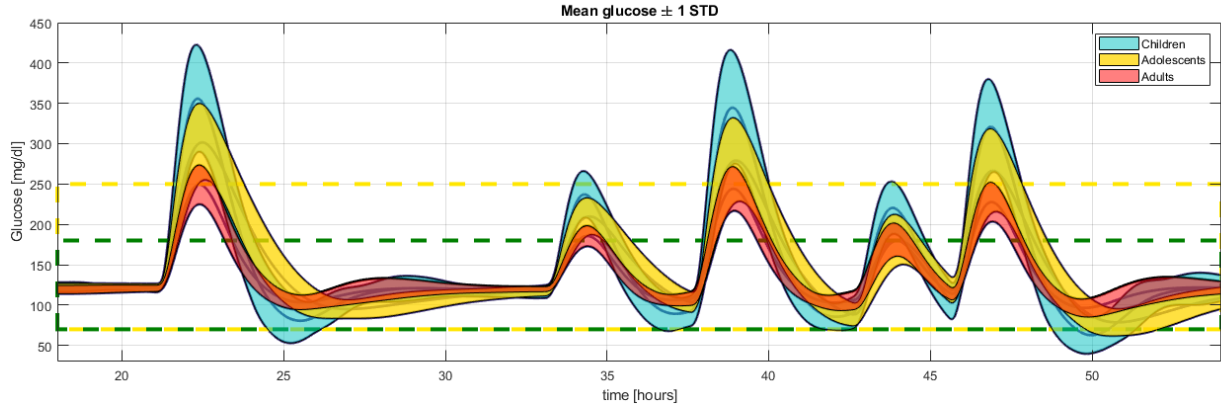

Fig. 1. Glycemia (mean \pm 1 std) vs time of the three age ranges when facing 5 meals during 36 hs using the ARG controller (10 adults - red, 10 adolescents - yellow, 10 children - cyan). Dashed green lines delimit the desired range ([70-180] mg/dl) and the yellow show the acceptable range ([70-250] mg/dl).

the aggressive controller. Although promising results were obtained, more and more intensive trials are necessary to assess the controller performance. Particularly, trials involving children and adolescents are fundamental since these age groups often present poor glycemic control and respond to treatment significantly different from adults (Sherr, 2018). In children, this is mainly due to fear of hypoglycemia during the night, school hours, or whenever the caregivers are not present, resulting in the set of a higher BG target. On the other hand, adolescents are more prone to be affected by diabetic burnout and suffer from higher insulin resistance (Caprio et al., 1989). To this end, a clinical trial in collaboration with the pediatric hospital Garrahan in Buenos Aires is expected to take place at the beginning of 2020. Figure 1 shows the response of the different age groups to a 5 meal scenario similar to the one carried out at the HIBA using the ARG algorithm. It can be seen that children and adolescents present larger glucose excursions and more pronounced hypo- and hyperglycemic episodes. Therefore, it is reasonable to consider an enhanced control approach in order to control the pediatric population. A recent *in silico* study was carried out by the research group to evaluate a more adequate tuning of the ARG algorithm for children and adolescents (ARG_{mod}) (Fushimi et al., 2019). Even though this modified version of the ARG reduced hypoglycemia episodes more effectively, the time spent in hyperglycemia was increased.

In this paper, a further step on the ARG algorithm is given by introducing time-varying IOB constraints, aiming to be tested *in vivo* in the Garrahan clinical trials. The main controller is a combination of the ARG algorithm SLQG and the SAFE layer with an IOB limit according to an open-loop IOB profile. This kind of constraint is called Amplitude Enable (AE) (Fushimi et al., 2018). The proposed control strategy (ARG_{AE}) is then evaluated *in silico* and contrasted to the ARG algorithm and to its retuned version (ARG_{mod}).

2. MATERIALS AND METHODS

In this section, the ARG algorithm and the proposed ARG_{AE} are described.

2.1 The ARG Algorithm

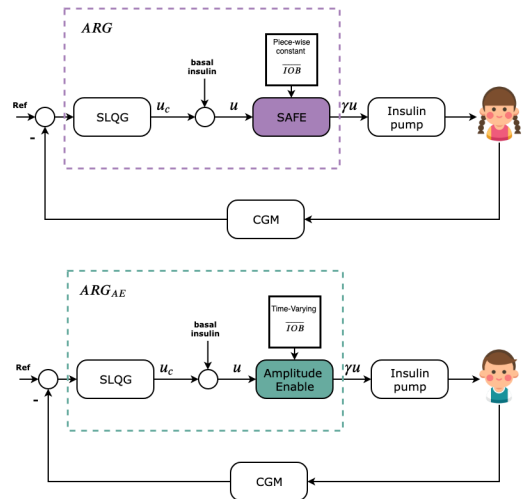

Fig. 2. Block diagram of the ARG and ARG_{AE} algorithms

The ARG algorithm regulates glycemia without delivering open-loop prandial boluses. Instead, it switches between an aggressive controller, which counteracts the effect of the meals, and a conservative controller, which is in charge of keeping the patient in the euglycemic range (BG \in [70 – 180] mg/dl) at all other times.

Figure 2 shows a block diagram of the ARG algorithm. The main controller in the ARG algorithm is a SLQG, that switches between an aggressive controller K_2 , which is in charge of compensating for the effects of the meals, and a conservative controller K_1 , which maintains glucose levels in the desired range at all other times. Therefore, while K_2 has to generate large insulin spikes to reduce the postprandial excursions, K_1 has to slightly modulate the basal insulin rate. To this end, the weighting matrices used to design controller K_2 are tailored to generate a faster and more aggressive response than controller K_1 (see details in Colmegna et al. (2018)). The output of this block is the insulin dose calculated by the SLQG (u_c).

In its current state, the switching between K_1 and K_2 is made using a meal announcement. The announcement triggers a *listening* mode in which the controller waits to

detect an increasing trend on CGM readings to switch to K_2 . It is worth highlighting that the meal announcement is not used to deliver meal priming boluses and no CHO counting is required. Instead, the user informs the size of the meal using one of three categories: small, medium and large. This information is used to tune the SAFE layer. On the other hand, the switching between K_2 and K_1 occurs automatically after one hour.

Since the controller does not have integral action, the open-loop basal insulin is added to u_c , yielding u . The signal u would command the insulin pump if the SAFE layer was not present. However, the SAFE modulates u through the signal γ ($\gamma \in [0, 1]$) in order to avoid violating an imposed restriction on the insulin-on-board (IOB). Therefore, the insulin dose that is finally delivered to the patient is γu . Currently, the SAFE layer in the ARG algorithm uses piecewise constant IOB constraints depending on the announced meal size, according to the following equations (1):

- Small meals < 35 gCHO:

$$\overline{IOB} = IOB_{ss} + 40 \text{ gCHO/CR.}$$
- Medium meals $[35, 65)$ gCHO:

$$\overline{IOB} = IOB_{ss} + 55 \text{ gCHO/CR.}$$
- Large meals ≥ 65 gCHO:

$$\overline{IOB} = IOB_{ss}(t) + 70 \text{ gCHO/CR.}$$

Where IOB_{ss} is the IOB with the basal insulin infusion, and CR is each patients carbohydrate ratio.

The ARG algorithm has been validated *in vivo* in 5 adult patients at the HIBA clinical trial. Although results were encouraging, *in silico* evaluation showed that the performance worsened when controlling the pediatric population (Fushimi et al., 2019). In that study, a modification in the ARG was proposed. As shown in figure 1, hyper- and hypoglycemia are more prominent for children and adolescents than for adults. In order to avoid hypoglycemia episodes, the \overline{IOB} was reduced to %80 of the value obtained using (1). On the other hand, to reduce hyperglycemia, the switching between K_1 and K_2 was reformulated: the listening mode was eliminated and the commutation from conservative to aggressive was made immediately after a meal was announced. Then, the controller switched from aggressive to conservative only when a decreasing trend in CGM readings was detected. This modified version of the ARG (ARG_{mod}) showed improved performance in hypoglycemia prevention at the cost of larger time periods in hyperglycemia.

2.2 The ARG Algorithm with Amplitude Enable (ARG_{AE})

According to Goodwin et al. (2015), the theoretically optimal treatment for glucose regulation is the basal-superbolus open-loop therapy. However, high uncertainty present in meal size and composition, patient parameters, and sensor readings make closed-loop control necessary. With this in mind, an IOB limitation strategy based on open-loop therapy was introduced, called the AE (Fushimi et al., 2018).

The AE block has the same working principle as the SAFE. The difference lies on the shape of the \overline{IOB} . For the SAFE, \overline{IOB} is a constant piecewise function while, for the AE, \overline{IOB} is a time-varying constraint shaped as the open-loop

therapy IOB profile multiplied by a constant $\beta > 1$, in order to give the controller an extra degree of freedom.

The shape of the IOB constraint used for the AE mode has the advantage of allowing large insulin doses at the beginning of the meal, and reducing them gradually as the meal effect ends.

The AE layer, like the SAFE, can work around any main controller. Here, it is combined with a switched strategy (the ARG algorithm), since using a very aggressive controller might generate unwanted oscillations (Fushimi et al., 2019), and a conservative one might not be strong enough to compensate large perturbations like the meals. In order to compute the \overline{IOB} , the meal classification is used. Like the ARG_{mod} , the switching between K_1 and K_2 is made when a meal is announced, and from K_2 to K_1 when BG decreases.

An illustrative example of the ARG and the ARG_{AE} is shown in figure 3. It can be seen that the insulin response generated by the ARG_{AE} is similar to a superbolus: large insulin spikes at meal time, followed by a cut in basal insulin delivery. The AE allows this non-linear behaviour to an otherwise linear controller like the LQG.

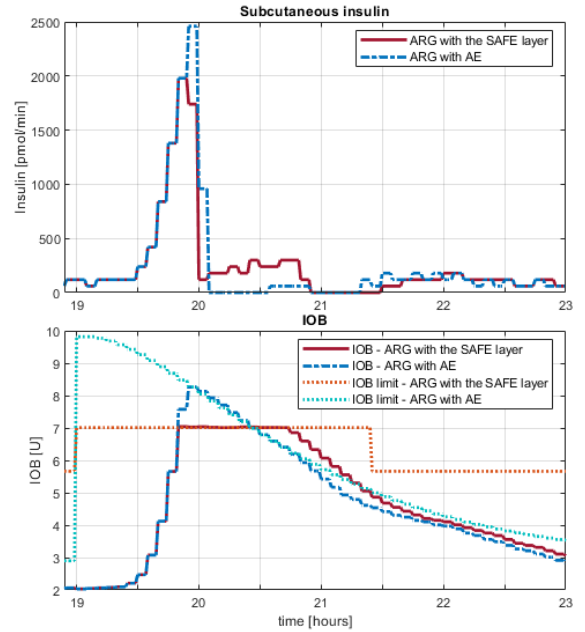

Fig. 3. Example of the \overline{IOB} , IOB and resulting insulin dose for the ARG with the SAFE layer (red) and for the ARG_{AE} (blue).

2.3 *in silico* Analysis

First, the ARG with the amplitude enable layer (ARG_{AE}) is evaluated considering a medium-sized meal for different values of β using the adolescent and children age groups available in the UVA/Padova simulator, and contrasted with the ARG, and its modified version (ARG_{mod}). The meal is announced at the time of intake, with the appropriate meal classification (medium).

Then, according to the first set of simulations, an adequate value for β is selected. Here, hypoglycemia reduction

is prioritized over hyperglycemia. For the second set of simulations, meal size error is considered using a small and a large-sized meal while announcing a medium meal.

For all simulations, meal intake takes place at $t = 1$ and is followed by a 9 hour post-prandial observation period. CGM noise is also considered using a DEXCOM CGM model provided in the UVA/Padova simulator.

3. RESULTS

3.1 Medium-sized meal - β sweep

Table 1 shows the mean ± 1 std of the % time in hyperglycemia ($>180\text{mg/dl}$), hypoglycemia ($<70\text{mg/dl}$), severe hyperglycemia ($>250\text{mg/dl}$), the desired range ($70\text{-}180\text{mg/dl}$) and the acceptable range ($70\text{-}250\text{mg/dl}$) for the 10 adolescents available in commercial version of the UVA/Padova simulator using the ARG , the ARG_{mod} and the ARG_{AE} for a 55 gCHO meal. It can be observed that while the ARG_{mod} reduces hypoglycemia, it significantly increases time spent in hyperglycemia. On the other hand, ARG_{AE} achieves the same reduction of hypoglycemia episodes, while also diminishing hyperglycemia when an adequate β is selected. In this case, a $\beta = 1.4$ achieves the most time in the desired and acceptable range (grey column).

Figure 4 shows the mean insulin delivered over time for the ARG , the ARG_{mod} and the ARG_{AE} with $\beta = 1.4$. As expected, the ARG_{AE} administers larger doses of insulin at the beginning of the meal and cuts insulin afterwards, slowly returning to basal delivery when BG values start to decrease. On the other hand, the constant IOB in the ARG and the ARG_{mod} results in a more distributed insulin dosage by the end of the meal. This causes a larger hyperglycemia peak with a higher risk of postprandial hypoglycemia. The result of this behaviour is illustrated with adolescent #004 in figure 5. It can be observed that the ARG_{AE} generates the same high peak in BG as the ARG , while achieving higher postprandial BG values as the ARG_{mod} .

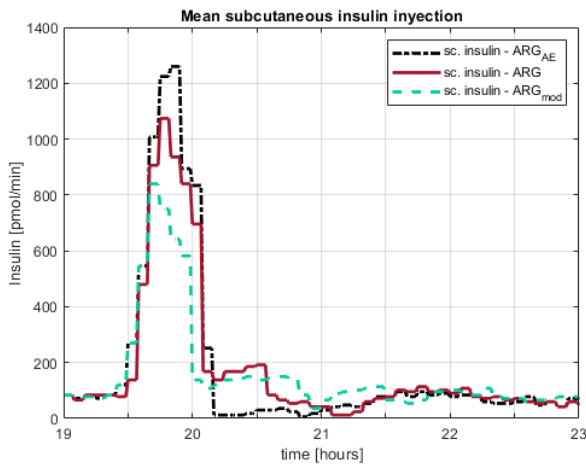

Fig. 4. Mean insulin infusion for a 55 gCHO meal using the ARG (solid red), the ARG_{mod} (dashed blue) and the ARG_{AE} with $\beta = 1.4$ (dashed-dotted black).

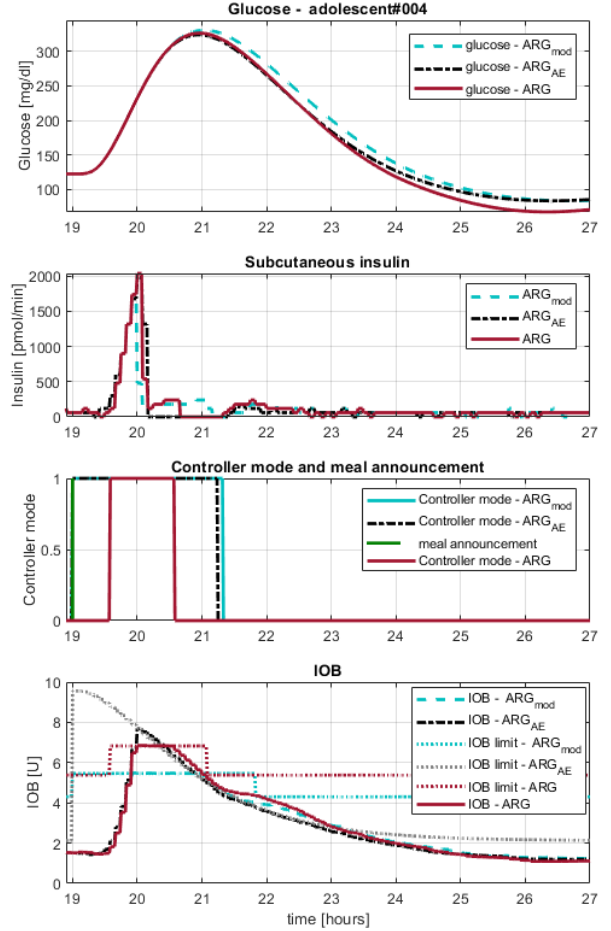

Fig. 5. Glucose, insulin, controller mode and IOB evolution over time of adolescent 4 of the UVA/Padova simulator using the ARG (solid red), the ARG_{mod} (dashed blue) and the ARG_{AE} with $\beta = 1.4$ (dashed-dotted black).

Table 2 shows the same metrics as table 1 but for the 10 children available in the UVA/Padova simulator, also for the ARG , the ARG_{mod} and the ARG_{AE} with different values of β . In this case, the ARG_{AE} further reduces the time in hypoglycemia achieved by the ARG_{mod} . However, if hypoglycemia reduction is prioritized, time in hyperglycemia is slightly increased compared with the ARG . Nonetheless, time in range is significantly improved.

3.2 Overestimated announced meal

Here, a 40 gCHO (small) meal is considered but a medium meal is announced in order to evaluate the algorithms performance when meals are overestimated.

Table 3 shows the same metrics as table 1 for the 10 adolescents available in the UVA/Padova simulator using the ARG , the ARG_{mod} and the ARG_{AE} with $\beta = 1.4$. Since the meal is overestimated, the time spent in hyperglycemia is lower for all control strategies compared with the 55 gCHO meal. Also, hypoglycemia is increased for the ARG . It can be noted that as the ARG_{mod} has the most restrictive IOB , it presents the highest mean time in hyperglycemia, but effectively avoids hypoglycemia episodes. On the other hand, hypoglycemia is reduced with

Table 1. Results (% of time) for the 10 adolescents of the UVA/Padova Simulator using the ARG , ARG_{mod} and ARG_{AE} with different values of β . Results are mean \pm 1 std. Meal size: M 55 gCHO (medium). Announced meal size: Medium.

	ARG	ARG_{mod}	ARG_{AE} $\beta = 1.2$	ARG_{AE} $\beta = 1.25$	ARG_{AE} $\beta = 1.3$	ARG_{AE} $\beta = 1.35$	ARG_{AE} $\beta = 1.4$	ARG_{AE} $\beta = 1.45$
Hyperglycemia	23.1 +4.2	26.6 +5.0	24.6 +4.8	23.8 +4.7	23.1 +4.6	22.5 +4.4	22.0 +4.3	21.5 +4.3
Hypoglycemia	1.0 +3.2	0.0 +0.0	0.0 +0.0	0.0 +0.0	0.0 +0.0	0.0 +0.0	0.0 +0.0	0.5 +1.7
Severe hyperglycemia	11.7 +5.8	13.4 +6.3	11.5 +6.9	11.2 +6.7	10.9 +6.6	10.7 +6.5	10.5 +6.4	10.3 +6.3
Desired range	75.9 +6.5	73.4 +5.0	75.4 +4.8	76.2 +4.7	76.9 +4.6	77.5 +4.4	78.0 +4.3	77.9 +4.4
Acceptable range	87.3 +7.8	86.6 +6.3	88.5 +6.9	88.8 +6.7	89.1 +6.6	89.3 +6.5	89.5 +6.4	89.2 +6.9

Table 2. Results (% of time) for the 10 children of the UVA/Padova Simulator using the ARG , ARG_{mod} and ARG_{AE} with different values of β . Results are mean \pm 1 std. Meal size: 55 gCHO (medium). Announced meal size: Medium.

	ARG	ARG_{mod}	ARG_{AE} $\beta = 1.15$	ARG_{AE} $\beta = 1.2$	ARG_{AE} $\beta = 1.25$
Hyperglycemia	19.9 +3.3	23.8 +4.5	22.5 +4.9	21.3 +4.5	20.6 +4.2
Hypoglycemia	6.0 +8.8	1.2 +3.9	0.0 +0.0	0.0 +0.0	1.5 +3.3
Severe hyperglycemia	12.8 +4.5	15.4 +4.8	13.4 +4.8	12.6 +5.3	12.3 +5.2
Desired range	74.0 +7.1	75.0 +4.6	77.5 +4.9	78.7 +4.5	77.9 +4.6
Acceptable range	81.1 +8.3	83.3 +3.2	86.6 +4.8	87.4 +5.3	86.2 +6.6

Table 3. Results (% of time) for the 10 adolescents of the UVA/Padova Simulator using the ARG , ARG_{mod} and ARG_{AE} with $\beta = 1.4$. Results are mean \pm 1 std. Meal size: 40 gCHO (small). Announced meal size: Medium.

	ARG	ARG_{mod}	ARG_{AE} $\beta = 1.4$
Hyperglycemia	17.7 +4.2	20.1 +5.2	16.7 +4.3
Hypoglycemia	4.4 +9.3	0.0 +0.0	3.5 +6.2
Severe hyperglycemia	4.1 +5.6	4.6 +6.4	3.8 +5.3
Desired range	77.9 +10.6	79.9 +5.2	79.8 +6.6
Acceptable range	91.5 +10.6	95.4 +6.4	92.7 +7.7

the ARG_{AE} , while slightly lowering time in hyperglycemia as the ARG . If a more conservative β had been chosen in order to prioritize hypoglycemia prevention, hypoglycemia can be avoided using the ARG_{AE} . For example, with $\beta = 1.3$: % time in hyperglycemia = 17.5 ± 4.5 , hypoglycemia = 0 ± 0 , severe hyperglycemia = 3.9 ± 5.4 , the desired range = 82.5 ± 4.5 and the acceptable range = 96.1 ± 5.4 .

Table 4. Results (% of time) for the 10 children of the UVA/Padova Simulator using the ARG , ARG_{mod} and ARG_{AE} with $\beta = 1.2$. Results are mean \pm 1 std. Meal size: 40 gCHO (small). Announced meal size: Medium.

	ARG	ARG_{mod}	ARG_{AE} $\beta = 1.2$
Hyperglycemia	15.7 +3.2	18.1 +3.9	15.7 +3.5
Hypoglycemia	6.8 +9.0	3.3 +5.4	5.6 +7.5
Severe hyperglycemia	7.4 +3.9	8.5 +4.6	6.6 +4.0
Desired range	77.6 +7.1	78.5 +4.8	78.7 +5.1
Acceptable range	85.9 +8.8	88.2 +6.6	87.8 +7.4

Table 4 shows the same metrics as table 3 but for the 10 children available in the UVA/Padova simulator, also for the ARG , the ARG_{mod} and the ARG_{AE} with $\beta = 1.2$. In this case, the ARG and the ARG_{AE} show the same % of time in hyperglycemia, while the ARG_{mod} achieves the

highest reduction of hypoglycemia. However, like with the adolescent age group, if a more restrictive β were selected, the ARG_{AE} has the ability of obtaining similar results with lower hyperglycemia. For example, with $\beta = 1.15$: % time in hyperglycemia = 16.3 ± 3.6 , hypoglycemia = 3.1 ± 4.7 , severe hyperglycemia = 6.9 ± 4.1 , the desired range = 80.7 ± 2.6 and the acceptable range = 90.0 ± 4.9 .

3.3 Underestimated announced meal

Here, a 70 gCHO (large) meal is considered but a medium meal is announced in order to evaluate the algorithms performance when meals are underestimated.

Table 5. Results (% of time) for the 10 adolescents of the UVA/Padova Simulator using the ARG , ARG_{mod} and ARG_{AE} with $\beta = 1.4$. Results are mean \pm 1 std. Meal size: 70 gCHO (large). Announced meal size: Medium.

	ARG	ARG_{mod}	ARG_{AE} $\beta = 1.4$
Hyperglycemia	27.8 +4.2	32.0 +4.8	26.6 +4.6
Hypoglycemia	0.0 +0.0	0.0 +0.0	0.0 +0.0
Severe hyperglycemia	17.9 +4.6	20.4 +5.0	16.8 +4.8
Desired range	72.2 +4.2	68.0 +4.8	73.4 +4.6
Acceptable range	82.1 +4.6	79.6 +5.0	83.2 +4.8

Table 5 shows the same metrics as table 1 for the 10 adolescents available in the UVA/Padova simulator using the ARG , the ARG_{mod} and the ARG_{AE} with $\beta = 1.4$. Since the meal is underestimated, the time spent in hyperglycemia is higher for all control strategies, and hypoglycemia is avoided. It can be noted that as the ARG_{mod} has the most restrictive IOB , it presents the highest mean time in hyperglycemia. On the other hand, hyperglycemia and severe hyperglycemia are slightly improved with the ARG_{AE} .

Table 6 shows the same metrics as table 5 but for the 10 children available in the UVA/Padova simulator, also

Table 6. Results (% of time) for the 10 children of the UVA/Padova Simulator using the ARG , ARG_{mod} and ARG_{AE} with $\beta = 1.2$. Results are mean ± 1 std. Meal size: 70 gCHO (large). Announced meal size: Medium.

	ARG	ARG_{mod}	ARG_{AE} $\beta = 1.2$
Hyperglycemia	24.0 \pm 3.9	29.0 \pm 5.4	33.6 \pm 14.8
Hypoglycemia	4.0 \pm 6.5	0.6 \pm 1.8	0.0 \pm 0.0
Severe hyperglycemia	17.6 \pm 3.9	21.3 \pm 4.5	20.3 \pm 4.6
Desired range	72.0 \pm 5.5	70.5 \pm 5.0	66.4 \pm 14.8
Acceptable range	78.3 \pm 6.1	78.1 \pm 3.9	79.7 \pm 4.6

for the ARG , the ARG_{mod} and the ARG_{AE} with $\beta = 1.2$. In this case, hyperglycemia is increased when using the ARG_{mod} and the ARG_{AE} . However, hypoglycemia is avoided only with the ARG_{AE} , which is the primary goal specially when regulating BG in children since it can have the most severe consequences. Additionally, it is worth highlighting that children tend to eat rather medium to small-sized meals.

4. DISCUSSION

Simulations show that when the meal size is estimated properly, the ARG_{AE} has the ability of reducing hypoglycemia episodes as was done with the ARG_{mod} but without increasing (or even further lowering) time in hyperglycemia compared to the ARG . Thus, the compromise between prandial hyperglycemia and postprandial hypoglycemia is eliminated.

When meals are not classified adequately, the ARG_{AE} shows consistent robust performance in adolescents, unlike the ARG_{mod} . On the other hand, in the case of the 10 children of the UVA/Padova simulator when meals are overestimated, hypoglycemia might increase compared to the ARG_{mod} if β is too relaxed. However, β can be as conservative as necessary taking into account each patient habits. **A study involving long-term, online adjustment of the β parameter should be performed in the future for multi-day clinical trials.**

Another important upside of the ARG_{AE} is that its tuning is relative to the open-loop therapy. This is an advantage since it is more user-friendly, and can use the information from the traditional patient treatment.

5. CONCLUSIONS

A strategy for automatic glycemic regulation based on switched control and time-varying IOB constraints was introduced and compared with the previously tested ARG algorithm and a modified version of it proposed in previous work. The comparison is made *in silico* considering the pediatric population available in the UVA/Padova simulator, on account of the coming up clinical trials in collaboration with the Garrahan hospital. Simulations show that the proposed algorithm improves the performance of the ARG algorithm and is robust to misclassified meals, as well as providing intuitive tuning. Future work should include automatic meal detection in order to evaluate the response of the proposed algorithm to unannounced meals.

REFERENCES

- Abitbol, A. and et. al. (2018). Overnight glucose control with dual- and single-hormone artificial pancreas in type 1 diabetes with hypoglycemia unawareness: A randomized controlled trial. *Diabetes Technology & Therapeutics*, 20(3), 189–196.
- Bequette, B. (2012). Challenges and recent progress in the development of a closed-loop artificial pancreas. *Annu Rev Control*, 36, 255–266.
- Brazeau, A.S. and et. al. (2013). Carbohydrate counting accuracy and blood glucose variability in adults with type 1 diabetes. *Diabetes Res Clin Pract*, 99(1), 19–23.
- Caprio, S., Plewe, G., Diamond, M.P., Simonson, D.C., Boulware, S.D., Sherwin, R.S., and Tamborlane, W.V. (1989). Increased insulin secretion in puberty: A compensatory response to reductions in insulin sensitivity. *The Journal of Pediatrics*, 114(6), 963–967.
- Colmegna, P., Garelli, F., De Battista, H., and Sánchez-Peña, R. (2018). Automatic regulatory control in type 1 diabetes without carbohydrate counting. *Control Eng Pract*, 22–32.
- Fushimi, E., Rosales, N., De Battista, H., and Garelli, F. (2018). Artificial pancreas clinical trials: Moving towards closed-loop control using insulin-on-board constraints. *Biomed Signal Process Control*, 45, 1–9.
- Fushimi, E., Serafini, C., Battista, H.D., and Garelli, F. (2019). Evaluación pre-clínica de controladores para páncreas artificial en población pediátrica. In *XVIII Workshop on Information Processing and Control*.
- Goodwin, G.C., Mediolli, A.M., Carrasco, D.S., King, B.R., and Fu, Y. (2015). A fundamental control limitation for linear positive systems with application to type 1 diabetes treatment. *Automatica*, 55, 73–77.
- Haidar, A. (2016). The artificial pancreas: How closed-loop control is revolutionizing diabetes. *IEEE Control Systems*, 36(5), 28–47. doi:10.1109/MCS.2016.2584318.
- Mauseth, R., Hirsch, I., Bollyky, J., Kircher, R., Matheson, D., Sanda, S., and Greenbaum, C. (2013). Use of a "fuzzy logic" controller in a closed-loop artificial pancreas. *Diabetes Technology and Therapeutics*, 15(8), 628–633. doi:10.1089/dia.2013.0036.
- Revert, A., Garelli, F., Picó, J., De Battista, H., Rossetti, P., Vehi, J., and Bondia, J. (2013). Safety auxiliary feedback element for the artificial pancreas in type 1 diabetes. *IEEE Trans Biomed Eng*, 60 (8), 2113–2122.
- Sánchez-Peña, R. and et. al. (2018). Artificial pancreas: Clinical study in Latin America without premeal insulin boluses. *J Diabetes Sci Technol*, 12(5), 914–925.
- Sánchez-Peña, R.S. and Chernoavsky, D.R. (2019). *The Artificial Pancreas: Current Situation and Future Directions*. Academic Press.
- Sherr, J.L. (2018). Closing the loop on managing youth with type 1 diabetes: Children are not just small adults. *Diabetes Care*, 41(8), 1572–1578.
- Shi, D., Dassau, E., and Doyle, F.J. (2019). Adaptive zone model predictive control of artificial pancreas based on glucose- and velocity-dependent control penalties. *IEEE Transactions on Biomedical Engineering*, 66(4), 1045–1054.
- Steil, G. (2013). Algorithms for a closed-loop artificial pancreas: The case for proportional-integral-derivative control. *J Diabetes Sci Technol*, 7(6), 1621–1631.